

Unit Information for Transportation

External Length	2506mm
External Width	1326mm
External Height	1958mm
Approx. Weight	511kg

Construction: Standard - One Piece  
 Dimensions: 2400 x 1220 x 1800mm (Internal)  
 Finish: Textured - 14 C 39 - British Racing Green  
 Doors: 1 x Double Doors - 800 x 1550mm  
 Door Lock: 3 Way Locking c/w Padlockable L Handle  
 Vents: 1 off 300 x 300mm Aluminium Vent  
 Roof Type: Explosion Relief - Dual Pitch - 9mm Soffit  
 Extras: Vent Pipe Holes & Gas Boards (Side Walls)

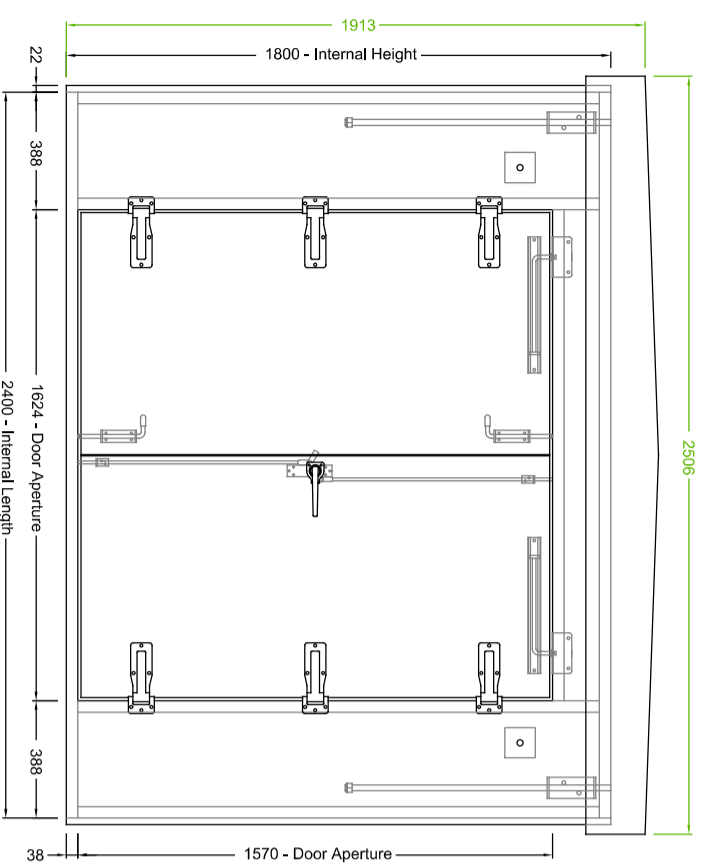

FRONT ELEVATION

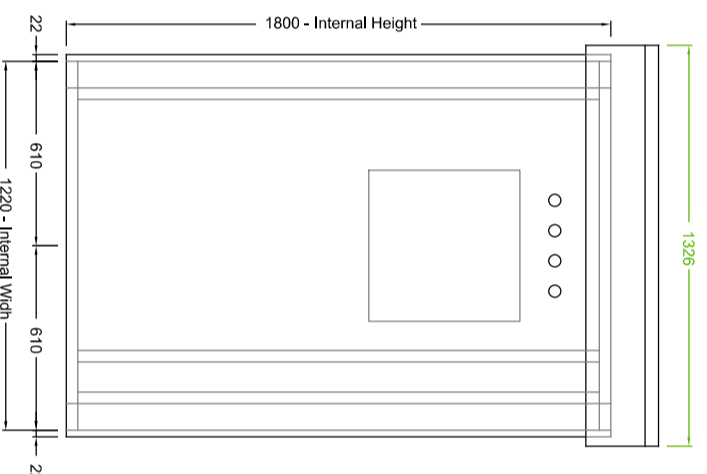

RH SIDE ELEVATION

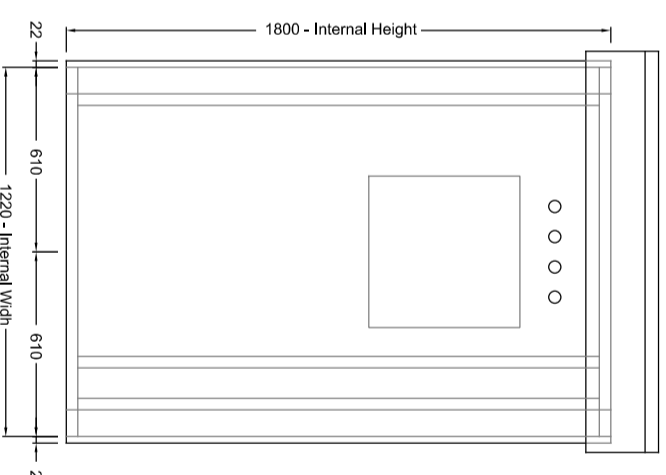

LH SIDE ELEVATION

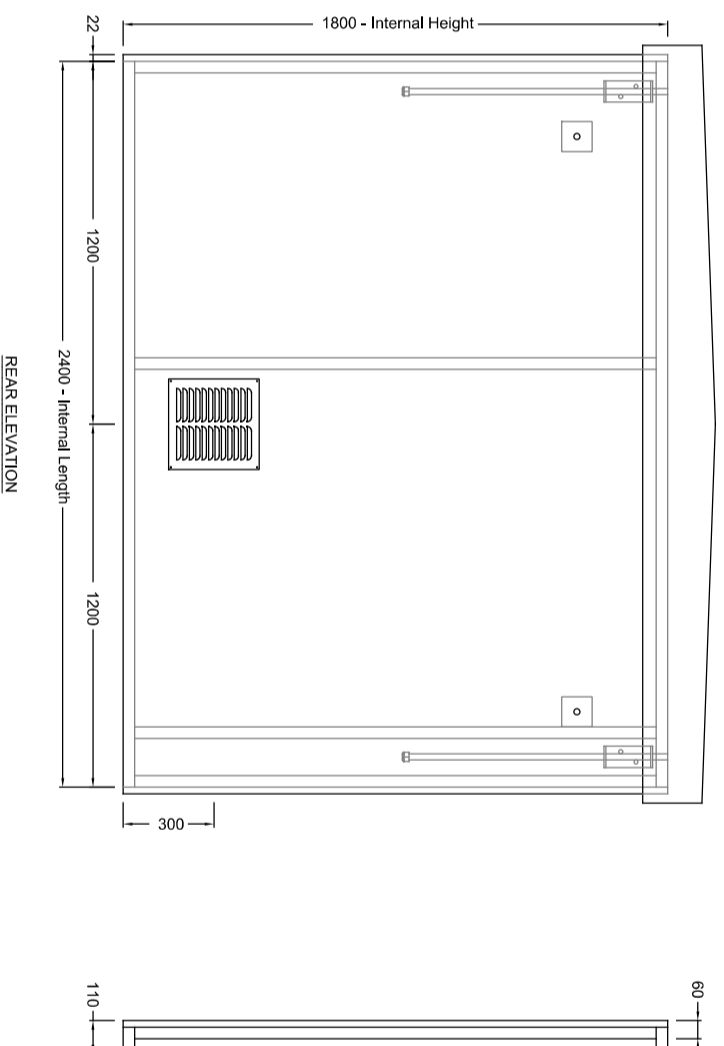
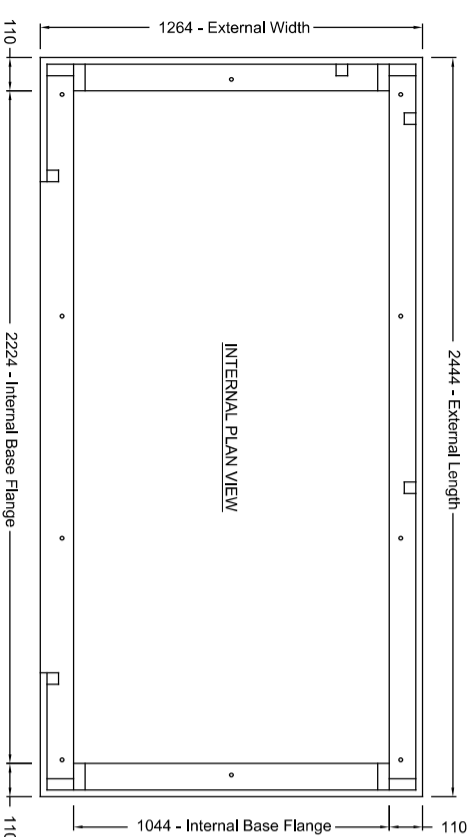

REAR ELEVATION

Vent Calculations									
GRP Kiosk Dimensions	2400	x	1220	=	2928000	mm <sup>2</sup>			
PRS35 Spec (3% Floor Area)	2928000	x	3%	=	87840	mm <sup>2</sup>			
Soffit Ventilation (mm)	9	x	7240	=	65160	mm <sup>2</sup>			
410 x 500mm Vents	0	x	69300	=	0	mm <sup>2</sup>			
300 x 300mm Vents	1	x	27137	=	27137	mm <sup>2</sup>			
Actual Ventilation %	92297	/	2928000	=	3.15	%			

Rev	Description	Drawn	Date
4	Internal ribs updated	MT	16.10.24

**Kingsley Plastics Limited**  
 The Airfield, Winkleigh, Devon. EX19 8DW  
 T: 01837 83154 www.kingsleyplastics.co.uk

Customer: **Gas Industry**

Project Name:

Drawing Title:

**GC8 Heavy Duty Kiosk**  
**General Arrangement**

SO No: **W/O No:**

Type: **Scale:**

**Overview** **1:25 (A3)**

Sheet: **Status:**

**1 of 1** **For Information**